

Electromechanical testing machines

LabTest 6.20 - 6.100L

The test frames of the LabTest L-series electromechanical testing machines with a capacity of up to 100 kN are ideal for static tests in tension, compression, bending and torsion with continuous, static and low cycle loading. These machines are widely used in testing materials and components where there is both small and large sample length.

Configurability and flexibility are the main advantages of this series. There are four basic test lengths and four basic workspace widths, which are available in desktop and rack versions with integrated or external measuring and control electronics. For maximum flexibility, one or optionally two test areas can be used.

For testing materials at different temperatures, LabTest L-series testing machines can be equipped with a temperature chamber that allows tests to be performed under specific temperature conditions. This fully digital test system with high precision includes automated computer control of test methods, which not only simplifies operation, but also greatly improves work efficiency.

Safety and reliability are ensured by the mechanical and electronic protection of the test frame against overload, run-over and impact, which contributes to the long service life of the device. This makes the LabTest L-series testing machines the ideal tool for reliable and precise material testing in various industrial applications.



Versatility, accuracy,
repeatability, performance
and affordability are
Our priorities...



Type of tests
Universal tensile, compression, and bending tests

Industry
engineering, plastics, construction,
automotive, research institutions and
schools, etc.

Key features and benefits of the L series

We use new technologies and emphasize safety...



Trial frames

The LabTest test frame is designed for maximum robustness and accuracy, ensuring reliable performance in a wide range of tests. Its high rigidity and precise crossbeam guidance guarantee coaxiality, high static and dynamic load carrying capacity and resistance to off-axis loads. The frame uses a linear guide with a profile rail and a preloaded carriage. The vertical movement of the crossbar is controlled by ball screws with an integrated lubrication system, which ensure accurate and repeatable positioning.



Force sensors

In our LabTest testing machines, we use LTx Force force sensors of our own production as well as sensors from renowned manufacturers, which can be calibrated in accordance with ČSN EN ISO 7500-1 and ASTM E4-21 standards. All force transducers have several key features in common: tensile and compressive measurement, high accuracy – accuracy class 0.02 to 0.05, extreme overload capacity of up to 100% of the nominal force. Each force transducer is equipped with an EEPROM that allows automatic identification of the load cell, storage of calibration constants and linearization at multiple points for tension and compression.



Powerful and precise AC servo drive

LabTest testing machines are equipped with powerful, dynamic and maintenance-free AC servo drives, which provide exceptional accuracy and reliability during testing. These drives ensure consistent speed even at extremely low values, down to 0.001 mm/min, which is essential for performing high-precision tests. With a feedback encoder resolution of up to 131,072 pulses per revolution, these servo drives provide excellent positioning accuracy and motion stability even at very low speeds, ensuring a fast and accurate response to changes during testing.

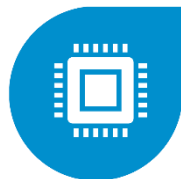

Measuring and control electronics

LabTest testing machines are equipped with powerful measuring and control electronics that ensure precise control of the tests. Two variants are available: EDCi20x for static applications with a maximum test frequency of 5 Hz and a data communication rate of 2.5 kHz. It has 3 external slots (expandable to 16) and an effective tensile/compression resolution of $\pm 1,000,000$ pieces. The electronics support automatic sensor identification, tension/compression linearization, and zero force correction. The PC interface includes USB 3.0 and Ethernet 10/100 Mbit. The electronics meet CE standards and include ECO



Remote control of the machine

The remote control of LabTest testing machines ensures high comfort and flexibility in the control of test processes. We offer a variety of actuator variants, including RMCi6, RMCi7, RMCi10 models. All controllers are designed with ergonomics in mind according to the ČSN EN 614-1+A1 standard, which ensures easy and comfortable use. Users can set any speed and perform test crossbar stepping directly on the controller. This approach increases the flexibility and efficiency of testing, while at the same time paying attention to ergonomics and operator comfort (controllers are not part of the basic range).



Touch monitor as part of the machine

LabTest L-series testing machines are equipped with integrated touch monitors that are part of the machine. The monitors are placed on a special hinge, allowing easy adjustment in both horizontal and vertical positions. The monitors run Test&Motion+ software with a virtual machine controller, which replaces the need for external RMCi controllers. This innovation ensures more comfortable operation and increases user comfort.



Test&Motion+ Testing Software

It is included with every LabTest testing machine and is designed to increase productivity and quality testing. This intuitive software allows tests to be performed efficiently and accurately with a customizable environment for measuring the mechanical properties of materials. The user-friendly interface on the LCD touchscreens makes operation easy. It supports international standards (EN, ISO, DIN, ASTM, GOST) and allows the creation and management of test methods for different types of tests. It provides instant and accurate results, facilitates integration with automation systems, and offers easy export

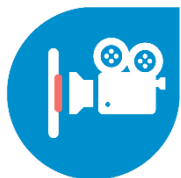

Testing accessories

LabTest testing machines are designed with flexibility and adaptability in mind, allowing for easy integration of different types of accessories. The most commonly used include VIDEO extensometers for non-contact measurement of deformations, temperature chambers and high-temperature furnaces for metal testing according to the ČSN EN ISO 6892-2 standard. These components allow tests to be carried out at various temperatures, including extremely high. Protective safety covers, designed in accordance with the EN ISO 14120 standard, ensure a safe working environment and operator protection.

Specification of testing machines LabTest 6.20 – 6.100L

Ratings	Units	LabTest 6.20L	LabTest 6.30L	LabTest 6.50L	LabTest 6.100L
Product code		1.05030724	1.05040924	1.05051124	1.05060824
Test force	Cn	20	30	50	100
Machine configuration		Two-column table or stand design with internal or external electronics			
Measurement accuracy		Better than +/- 0.5% read down to 1/1000th of load cell capacity			
Workspace					
Width of the working area (D)	mm	460	460	460	460
Test area height – lower (E1)	mm	1100	1100	1080	1345
Test Compartment Height - Upper (E2) ¹	mm	1110	1110	1090	1355
Trial frame – tabletop version					
Machine height – benchtop version (A)	mm	1530	1530	1530	1833
Machine width with integrated electronics (B) – MI version – desktop version	mm	877	877	877	820
Machine width with external electronics (B) – MO ² version	mm	1006	1006	1006	949
Machine depth - benchtop version (C)	mm	663	663	663	600
Trial frame – rack version					
Machine height – rack version (A)	mm	1760... 2110	1760... 2110	1760... 2110	-
Machine width with integrated electronics (B) – MI version – stand version	mm	900	900	900	-
Machine width with external electronics (B) – MO ² version	mm	1029	1029	1029	-
Machine depth - rack version (C)		900	900	900	-
Electric drive					
Crossbar speed – min	mm/min	0,0005	0,0005	0,0005	0,0005
Crossbar speed – max ³	mm/min	1000	1000	1000	500
Crossbar speed – return ³	mm/min	1500	1500	1300	650
Precision speed control	%	+/- 0,1	+/- 0,1	+/- 0,1	+/- 0,1
Position repeatability	µm	±1.5	±1.5	±1.5	±1.5
Machine drive differentiation	µm	0,00508	0,00771	0,00508	0,00191
Cycle time	Hz	2500	2500	2500	2500
Engine type		AC servo motor with high torque thanks to special winding			
Feedback Position Measurement		17-bit absolute magnetic encoder with min resolution of 131,072 imp			
Controller		Fully digital, pulse frequency 4MHz, communication interface EtherCAT, CAN open...			
Electrical connection					
Supply voltage/frequency	V/Hz	115 or 230/50-60/1 phase			
Machine power consumption	Kva	1,3	1,3	1,3	1,3
Other parameters					
The basic weight of the machine without	Kg	120	120	192	245
Machine noise at V max ⁴	dB	67	67	67	67
Color combination	RAL	1015, 5015			
Interface to PC ⁵		USB, Ethernet			
Environmental conditions					
Working Environment Temperature	°C	+10 ... +35			
Humidity of the working environment	%	<90			

¹ The upper working space is not in the foundation of the testing machine (as, accessory)

² Measuring and control electronics are located on a swivel joint

³ If a protective cover is not included in the testing machine, the return test speed is limited in accordance with EN ISO 12100 and EN ISO 14120

⁴ The measurement of machine noise is in accordance with the ČSN EN ISO 3745 standard - Acoustics - Determination of sound power levels ...

⁵ More information on page 5

⁶ Machine width is without monitor

Version types of LabTest testing machines 6.20 to 6.100L

Type 6.20 to 6.50L – stand version SV

MI version – electronics in the machine
4 standard heights of test spaces

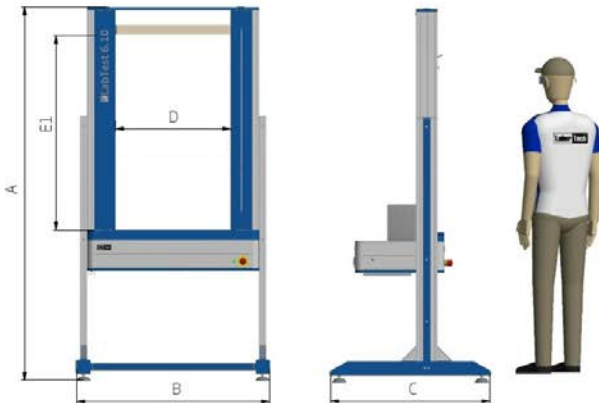

Type 6.20 to 6.50L – stand version SV

MO version – electronics separately on the machine
4 standard heights of test spaces

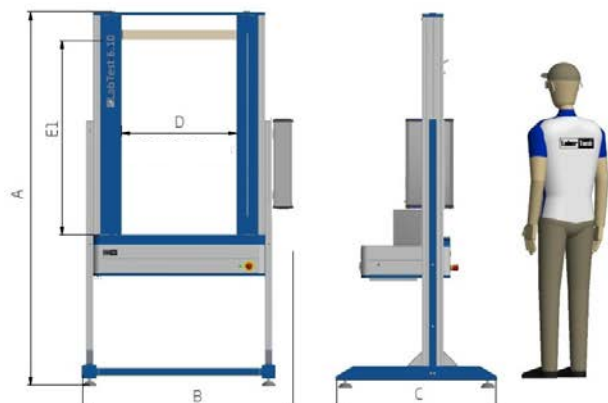

Type 6.20 to 6.100L – DV desktop version (desktop)

MI version – electronics in the machine
4 standard heights of test spaces

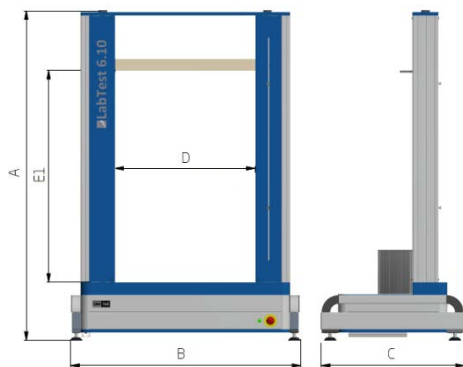

Type 6.20 to 6.100L – desktop version DV

MO version – electronics separately on the machine
4 standard heights of test spaces

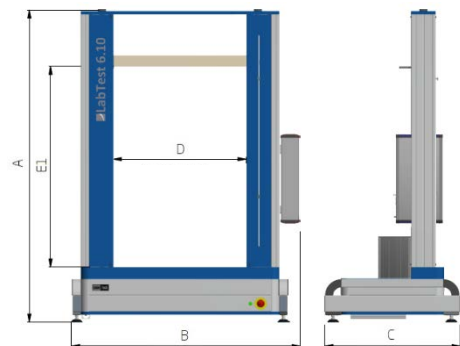

Various customer variants

We offer more than 50 customer variants
We also deliver customized customer applications
For more information, please contact [our sales representative](#)



LabTest L Series Machine Electronics

Ratings	Units	Parameters
Electronics for static applications and low cycle fatigue		EDCi20x (2.001030117)
Number of external slots (expandable to 16)		3
Speed of data communication with a PC	kHz	2,5
Maximum test frequency of the machine	Hz	5
Electronics for static and dynamic applications¹		EDCi70x (2.001050117)
Number of external slots (expandable to 16)		8
Speed of data communication with a PC	kHz	10
Maximum test frequency of the machine	Hz	300
Other common parameters		
Real-time channel synchronization		YES
Bit accuracy of internal controller	bit	64
Control loop speed	kHz	2,5
Adjustable system time	µs	400/500/600... 1000
Internal processing of measured analog quantities	bit	32
Calculated Resolution – Tension/Compression	bit	21
Effective resolution in tension / compression at the time of integration	sample	± 1,000,000 (100ms)
Standard resolution in tension / compression	sample	± 250,000 (20ms)
Speed of reading of measured analog quantities	kHz	20
PC interface		USB 3.0, Ethernet 10/100 Mbit
Measurement accuracy class		0,5/1, depending on load cell, calibration of load cells in accordance with ISO 7500-1, ASTM E4-21
Linearization of tension/compression sensors separately		YES
Automatic sensor identification		YES
Detection and LOG of exceeding the max. force F of the sensor		YES
Zero Force Correction		YES – automatically
Possibility to connect these input channels and quantities		iDCA – Strain Gauges Multi Analog ICs Digital ICs Analogue ± 10 iCFA – LVDT and 10 V analogue ± strain gauges iINC – two incremental (A/B/R) or SSI interfaces iADA – four analog outputs and four analog inputs (+/- 10 V) iIO – 24 V DC IO (8 outputs, 8 inputs) iINCX – two incremental interfaces (A/B/R) with RS485 to MFX
Possibility to connect a remote control of the machine		YES
Types of remote control		RMCi6, RMCi7, RMCi10
ECO mode		YES
E-Stop by		ČSN EN ISO 13850 with monitoring
CE conformity		pursuant to the Machinery Directive 2006/42/EC
Electrical connection		
Supply voltage/frequency - external electronics - MO	V/Hz	115 or 230/50-60/1 phase
Supply voltage/frequency - internal electronics - MI	V/DC	24
Other parameters		
Basic dimensions of external electronics – MO	mm	99 x 463 x 244
Color combination of external electronics – MO	L	Alu, graphite grey
Environmental conditions		
Working Environment Temperature	°C	+10 ... +35
Humidity of the working environment	%	<90

¹ EDCi 70 Electronics are available at an additional cost. The electronics are not integrated in the

The elements that characterize us...

We offer everything from development to implementation and listen to your needs...



Warranty and post-warranty service

From the moment our machines are delivered, our commitment does not end. We pride ourselves on standing behind our products and customers even after they leave our company. In order to ensure maximum satisfaction and peace of mind with our devices, we provide a complete online warranty and post-warranty service. Thanks to our dedicated team of experts, we are here to provide you with the best possible support throughout the entire lifecycle of our products. With our online warranty and post-warranty service, you are safe, aware of our support whenever you need it.



Ecological approach

We are proud to be a company that not only develops and manufactures quality testing machines and equipment, but also takes the environment seriously. For us, ecology is not just a phrase, but an essential aspect of our business. We are committed to minimal environmental impact and sustainable working practices. Our commitment to the environment does not end with the possession of the ISO 14001:2016 certificate. We believe that every step towards sustainability is crucial for the future of our planet.



Simple operation

In the company, our company emphasizes quality training and training for the operation of our machines. We believe that expertise and ease of use are key factors in achieving optimal results and customer satisfaction. When developing our devices, we focus not only on performance and innovation, but also on ease of use. This allows for quick adaptation and efficient work even for less experienced users. We are here to ensure that our technologies are not only powerful, but also easy to use for all users.



Reliability, accuracy and repeatability of measurements

With LabTest test machines, accuracy and repeatability of force and displacement measurements are our top priority. We have combined these key aspects with high dynamics of electronics to guarantee a more affordable and efficient way to set up our devices. Thanks to the innovative approach to electronics in our testing machines, we have achieved excellent accuracy and repeatability in the testing process. The reliability of our equipment is important not only for research and development, but also for industrial and testing applications.



Versatility and versatility

Our LabTest testing machines have a double advantage: versatility and intuitive operation, which brings efficiency during the tests themselves. By combining our high-quality testing machines with highly functional accessories, we offer versatility for a wide range of testing needs. This flexibility allows our customers to perform different types of tests and measurements with one device, which is an economic and practical benefit. Thanks to these features, you can rely on precise results and trouble-free operation in everyday practice.



Safety at the highest level

We strongly promote safety at the highest level in accordance with the latest directives 2006/42/EC and 2023/1230 and industry standards such as IEC 60947. Every product we create is the result of many years of experience, research and experimentation in the field of mechanical testing of materials. Our compliance with standards is documented by the EC and EU Declaration of Conformity, which is why we leave nothing to chance.



Mechanical resistance and maintenance-free operation

When developing products, we emphasize that LabTest machines have robustness, rigidity, long service life, mechanical resistance and maintenance-free operation – these are our key priorities. Our offer includes professional engineering and consulting services, which harmoniously blend in the design of systems and the implementation of the tests themselves.